



EZ53

Tracked Zero Tail Excavators



Best performance of its class

High excavation performance even in hard to reach areas. The EZ53 is the perfect equipment for operations close to walls or buildings. The tail of the EZ53 does not reach over the undercarriage in no operating position at any time. The minimized space requirements are extremely practical on construction sites in busy city centers or on road construction sites with ongoing traffic. But not only its operating dimensions are convincing, also its material handling and digging performance are impressive.

- Remarkably higher engine and hydraulic performances plus reduced fuel consumption at the same time.
- Maintenance made easy: the tiltable cabin and the removable chassis cover provide quick and easy access, diagnostic tools offer further support.
- Perfectly equipped for multi-functional attachment tools: up to five additional control circuits with unpressurised reflux available.
- Numerous options available ex-factory such as: overload valves, idle speed autom. operation and more.

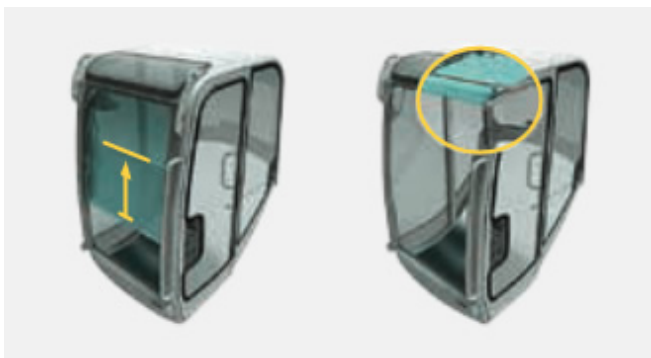

Comfortable cabin

- Spacious cabin for sufficient space for movement.
- Sliding windows on both sides. The front windscreen is divided in two. The lower screen slides up behind the upper, both screens can be moved under the cabin ceiling.



**WACKER
NEUSON**
all it takes!

Engine for highest performance

- Remarkably higher engine and hydraulic performances plus reduced fuel consumption at the same time.
- Improved digging performance and more powerful Turbo-Diesel engine provide better material handling results.



zero tail – compact all around

- Zero Tail Excavator for safe operation even in narrow spaces.
- Ideal for excavation jobs close to walls, roads, buildings or other surrounding limitations as in inner cities or busy roads.
- Optional counterweights improve stability.



**WACKER
NEUSON**
all it takes!

VDS – vertical digging system

- The first intelligent solution for highest efficiency of excavating jobs on sloping grounds.
- VDS is available as an option for the EZ53
- VDS makes excavating particularly economical and is therefore awarded with the ECO seal.
- More details on VDS under:

wackerneuson.com/vds





Technical specifications

Operating data

Shipping weight min.	4,961 kg
Operating weight	5,234 - 6,431 kg
Biting force max.	28 kN
Breakaway force max.	38.1 kN
Digging depth max.	3,751 mm
Dumping height	3678 - 3943 mm
Dump height max.	3,943 mm
Digging radius max.	6,233 mm
Superstructure slewing speed	9.2 1/min
L x W x H	5500 x 1990 x 2572 mm

Engine / Motor

Engine / Motor manufacturer	Perkins
Engine / Motor type	404D-22T
Engine / Motor	water-cooled 4-cylinder diesel engine
Displacement	2,216 cm ³
RPM / speed	1,900 rpm
Engine performance acc. to ISO	35.9 kW
Battery	88 Ah
Fuel tank capacity	83 l

Hydraulic system

Duty pump	Double variable- & two-gear pump
Flow rate	106.4 l/min
Operating pressure for working and traction hydraulics	230 bar
Hydraulic oil tank	80 l

Wheel set

Travel speed max.	4.7 km/h
Chain width	400 mm
Ground clearance	322 mm

Dozer Blade

Width	1,990 mm
Height	380 mm
Stroke above ground	415 mm
Stroke below ground	455 mm



**WACKER
NEUSON**
all it takes!

Sound level

Sound level (LwA) acc. to 2000/14/EC	94 dB(A)
Cabin - specified sound pressure level LpA acc. to ISO 6394	78 dB(A)



Dimensions

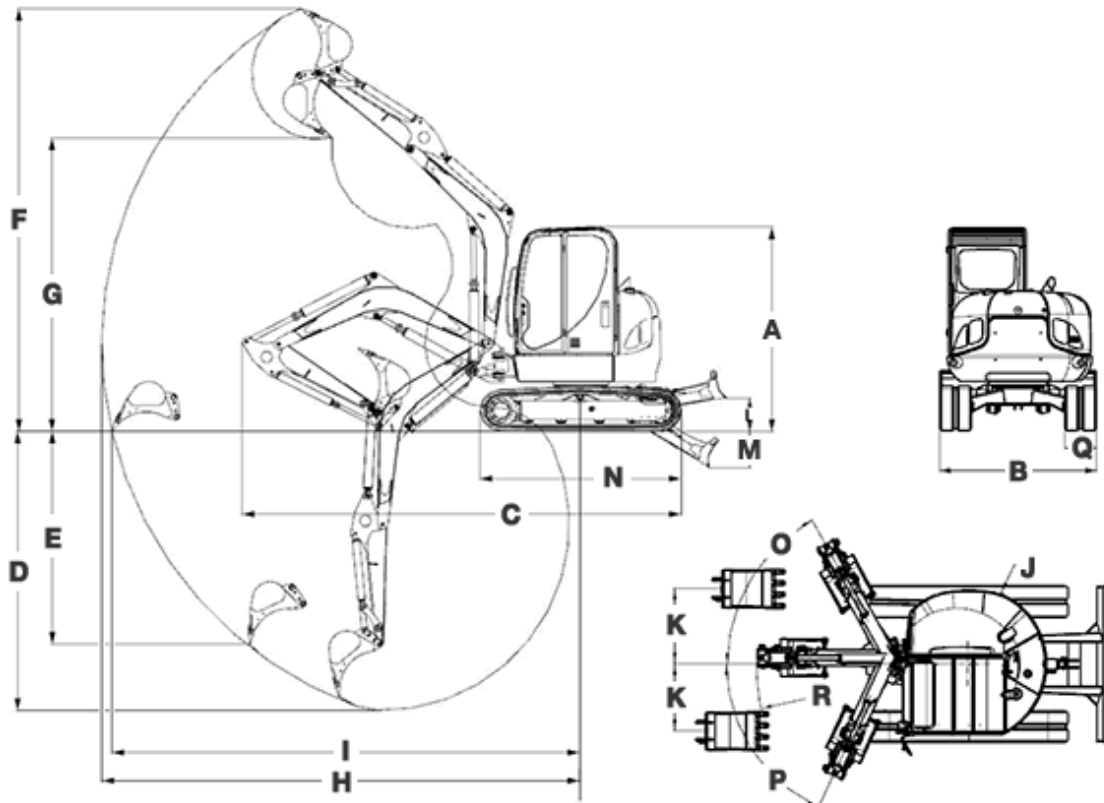

VDS

A	Height	2,572 mm	2,672 mm
B	Width	1,990 mm	1,990 mm
B	Width of the revolving superstructure	1,843 mm	1,843 mm
C	Transport length (short dipper stick)	5,498 mm	5,490 mm
C	Transport length (long dipper stick)	5,477 mm	5,496 mm
D	Digging depth max. max. (short dipper stick)	3,501 mm	3,394 mm
D	Digging depth max. max. (long dipper stick)	3,751 mm	3,644 mm
E	Insertion depth max. vertical (short dipper stick)	2,667 mm	2,542 mm
E	Insertion depth max. vertical (long dipper stick)	2,906 mm	2,781 mm



F	Insertion height max. (short dipper stick)	5,299 mm	5,405 mm
F	Insertion height max. (long dipper stick)	5,459 mm	5,564 mm
G	Dump height max. max. (short dipper stick)	3,678 mm	3,784 mm
G	Dump height max. Max. (long dipper stick)	3,837 mm	3,943 mm
H	Digging radius max. max. (short dipper stick)	5,987 mm	5,994 mm
H	Digging radius max. max. (long dipper stick)	6,225 mm	6,233 mm
I	Range max. ground coverage (short dipper stick)	5,860 mm	5,823 mm
I	Range max. ground coverage (long dipper stick)	6,104 mm	6,071 mm
J	Rear swivel radius	995 mm	995 mm
J	Rear swivel radius with counterweight	1,055 mm	1,055 mm
K	Arm displacement max. boom offset to center of bucket, left side	958 mm	958 mm
K	Arm displacement max. boom offset to center of bucket, left side	853 mm	853 mm
L	Lift height max. of the dozer blade above subgrade	415 mm	415 mm
M	Scraping depth max. of the dozer blade below subgrade	453 mm	453 mm
N	Length	2,524 mm	2,524 mm
O	Turning angle max. of the arm system to the right	61 °	61 °
P	Turning angle max. of the arm system to the left	65 °	65 °
Q	Chain width	400 mm	400 mm
R	Boom slewing radius center	2,692 mm	2,692 mm
R	Boom slewing radius right	2,431 mm	2,431 mm
R	Boom slewing radius left	2,289 mm	2,289 mm



**WACKER
NEUSON**
all it takes!

Please note

that product availability can vary from country to country. It is possible that information / products may not be available in your country. More detailed information on engine power can be found in the operator's manual; the stated power may vary due to specific operating conditions.

Subject to alterations and errors excepted. Applicable also to illustrations.

Copyright © 2016 Wacker Neuson SE.